

An insight into conversion of internal combustion engine (ICE) vehicle to electric vehicle for green transportation technology



Manoj A. Kumbhalkar^a✉ | Mhalsakant M. Sardeshmukh^b | Dattatraya V. Bhise^a |
Sumant A. Choudhari^c | Kishor S. Rambhad^d | Pramod H. Sahare^e | Narendra K. Ade^e

^aDepartment of Mechanical Engineering, JSPM Narhe Technical Campus, Pune, India.

^bDepartment of Electronics and Telecommunication Engineering, JSPM Narhe Technical Campus, Pune, India.

^cDepartment of Civil Engineering, JSPM Narhe Technical Campus, Pune, India.

^dDepartment of Mechanical Engineering, St. John College of Engineering and Management, Plaghar, India.

^eDepartment of Mechanical Engineering, Rajiv Gandhi College of Engineering, Research and Technology, Chandrapur, India.

Abstract An electric car is a type of alternative-fuel vehicle that uses electric motors and motor controllers instead of an internal combustion engine. Power is provided via battery packs rather than carbon emission-based fuel. It offers a variety of advantages over typical internal combustion engines, most notably lower local emissions and higher energy efficiency. The aim of this research is to modify the vehicle running with an internal combustion engine into an electric vehicle for transferring material from one place to another inside the industrial area. For this purpose, a Maruti 800 car model has been selected, and during the field work, all unwanted parts of the IC engine are removed to convert it into an electric vehicle. The analytical analysis has been carried out to calculate the power transmission capacity and the speed of the vehicle. The finite element analysis is also carried out to check the strength of reused parts like belt drives and crankshafts. A Simulink model of an electric vehicle is prepared to check its performance and provide suggestions during the vehicle's assembly. The vibration response has proven that the source vibration, the noise, vibration, and harshness (NVH) issues in electric vehicles (EV) differ significantly from those in internal combustion engines (ICE).

Keywords: energy, IC engine, electric vehicle, FE analysis, EV components

1. Introduction

An electric vehicle (EV) was the first to be demonstrated as a self-powered road vehicle in 1839. In the late nineteenth century, the internal combustion engine replaced the electric motor as the major power source for cars, ushering in the modern era of the automobile. In combination with sustainable power plants such as hydro, wind, nuclear, and solar power plants, EV adoption may efficiently keep clean air on the road, directly improving air quality.

In the roadmaps of the auto industry, the electric vehicle (EV) is seen as a key technology for the future of car power systems. The absence of EV infrastructure is a huge concern in Malaysia and Indonesia. As the largest automobile market in Southeast Asia, Indonesia has enormous potential. Automobile manufacturers have begun to invest in R&D in the electric vehicle (EV) business. The number of EVs has increased quickly in recent years as a result of improved technology and government attempts to reduce their environmental impact. Electric vehicles (EVs) are seen as a wonderful answer to this problem. Using sales data from 21 OECD nations, the study evaluates the influence of Hofstede's six characteristics of national culture on the growth of the electric vehicle industry. Government regulation for EVs remains a key non-technical obstacle, while charging time and battery performance are technical problems (Veza et al 2022; Ewelina and Grysa 2021; Alosaimi et al 2021; Wahid et al 2021; Novotny et al 2022).

Concerns about the environment in the 21st century have led to the rise of electric cars that run on batteries. The replacement of ICPVs with new EVs is helped by the relatively low cost of electricity in most countries, as well as by government subsidies and tax breaks. Even though the number of EVs on the market has grown a lot, making batteries and electric motors in large quantities is still the most difficult part of the supply chain. On average, the battery accounts for around 40% of the total cost of EV manufacturing. Massive quantities of data must be collected, analysed, and refined to ensure that EVs are safe for adoption. AFVs come in a variety of forms, the most well-known of which are battery electric vehicles (BEVs) and hydrogen fuel cell vehicles (HFCVs). The total cost of ownership (TCO) is a crucial factor in EV popularity. According to the European Consumer Organisation (BEUC), having an EV allows customers to save money and has a better long-term cost solution than



ICEs that utilise diesel and gasoline (Dotoli et al 2022; Lashari et al 2022; Vrabie 2022; Mamun et al 2022; Gandoman et al 2021).

Electric vehicles are a better way to get around that is cheaper and better for the environment, but their initial cost may keep people from buying them. Electric vehicles need many batteries to generate electricity, which may cost well over tens of thousands of dollars for marketed electric automobiles like the Tesla Roadster (da Silva and Urbanetz 2019; Ala et al 2021; Vu et al 2021; Xuan et al 2013).

This research is meant to help EV players in India find the best BEV product-market fit to encourage more people to buy electric cars. This work was carried out in the industry located in Pune, India. An IC-engine Maruti 800 vehicle is provided by the company to convert it into an electric vehicle for goods-carrying purposes inside the industry. The various pieces of the IC vehicle are removed, such as the piston and piston head, the fuel tank, the catalytic converter, the silencer, and the passenger seats, and it has been replaced with electric components, such as an electric motor, lead acid batteries, and a controller.

The work has been carried out in the industry located in Pune, India. The firm provides an IC-engine Maruti 800 vehicle for conversion into an electric vehicle for goods transport within the sector. The objectives of this research are to convert and modify IC into an electric vehicle using analytical and experimental techniques. The aim is to remove all unwanted parts such as the piston and piston head, the fuel tank, the catalytic converter, the silencer, and the passenger seats of the IC engine vehicle and replace them with electric components such as an electric motor, lead acid batteries, and a controller. The novelty is that a goods carrying electric vehicle has been developed with the constraints of an ICE vehicle. The gearbox has not been removed from the vehicle, and it has been used in the EV to maintain speed ratio. Also, the complete engine has been disassembled, but the cylinder block is used to place the motor, and the crankshaft is used to transmit power from the motor to the axle. With all these constraints, the vehicle has been prepared and tested in the industry.

The objectives of this research are to convert and modify IC into an electric vehicle using analytical and experimental techniques. The main components of an electric vehicle are shown in Figure 1 (GoMechanic 2022). This case study is carried out for an Indian IC engine vehicle made by Maruti Suzuki, model 800, shown in Figure 2, and its technical specifications are given in Table 1.

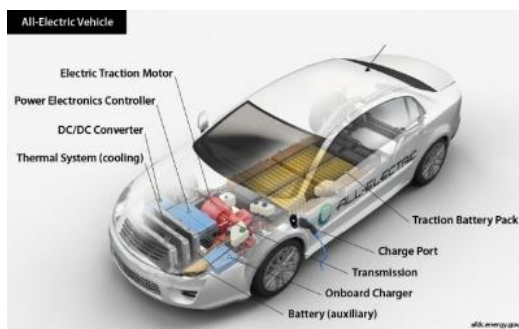

Figure 1 Electric vehicle components.



Figure 2 Maruti 800 ICE Model.

Table 1 Maruti 800 Specifications.

Sr. No.	Parameters	Values
1	Overall length	3,335 mm (131.3 in)
2	Overall width	1,440 mm (56.7 in)
3	Overall height	1,405 mm (55.3 in)
4	Wheelbase	2,175 mm (85.6 in)
5	Ground clearance	160 mm (6.3 in)
6	Kerb weight	650 kg (1,433 lb)
7	Gross vehicle weight	1,000 kg (2,205 lb)

The expansion of the high-temperature and high-pressure gases produced by combustion acts directly on a component of an internal combustion engine.

1.1. EV Technology

Veza et al (2022) highlights various major difficulties in the implementation of electric vehicles in Malaysia and Indonesia. Perodua and Proton are Malaysia's two national automobile manufacturers. In Indonesia, the vast quantity of motorbikes and the motorcycle growth rate imply that the present public transit infrastructure cannot satisfy the mobilisation demands. In 2019, Perodua had the greatest market share of 38%, with Honda coming in second with 17%, followed by Toyota and Proton.

Alosaimi et al (2021) identified numerous evaluation parameters, creation of a unified model for assessing performance, and calculation utilizing the fuzzy MCDM approach Although technological developments in transportation and civilization have



benefited life on Earth, they have also resulted in massive environmental degradation. As a result, people are becoming more concerned about the environment and its long-term viability. Renewable-energy vehicles contribute to global challenges. Transportation will be critical in energy systems based on mode interchange.

Novotny et al (2022) investigated the influence of national culture on the adoption of electric cars (EVs). They contributed to study on the factors that influence country variances in EV market share and market development. They evaluated associations in two years, covering a reasonably wide sample of nations and included numerous cultural characteristics. BEV sales are heavily influenced by culture, which is particularly obvious in nations whose cultural values are better aligned with the functional, innovative, and environmental benefits of BEVs.

Gandoman et al (2021) provides a complete review of the reliability evaluation of Li-ion batteries. The degradation circumstances from diverse discharge C-rates and ambient temperatures were studied in the test case to provide a better understanding of the idea of battery dependability from the CF perspective. According to the case study findings, the battery's dependability is poorer at 10°C and high discharge C-rate than in other settings.

Un-Noor et al (2017) study goes into great depth about the future of electric cars (EVs). The kinds, configurations, energy sources, motors, power conversion, and charging technologies of electric vehicles have been examined. Current EV limitations have been outlined, along with potential remedies to these deficiencies. The most recent optimization techniques and control algorithms are explained and a summary of the existing EV market has been provided. Trends and potential future developments have also been evaluated.

The electric vehicle layout is shown in Figure 3.

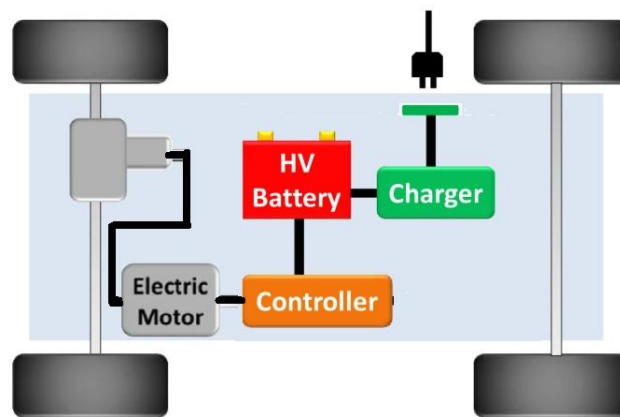

Figure 3 Electric vehicle layout.

1.2. Conversion of ICE to EV

da Silva and Urbanetz (2019) explained that at a modest cost, an ICE-powered Mercedes-Benz Class A 190 was converted into an EV. Several testings show that the conversion is feasible, with the automobile achieving an average travel cost of 0.16 R\$/km. Solar energy might be used to create power using photovoltaic panels, which would be an even more ecologically friendly approach.

Xuan et al (2013) and Vrazic et al (2014) showed that converting an internal combustion engine (ICE) sports motorbike into a converted battery-powered electric vehicle (CBEV) may lead people to think that such an ICE-to-BEV conversion will always have net positive environmental benefits. But the energy and material costs of converting a CBEV are weighed against the money saved while using the vehicle after the conversion. These findings are significant for the present global transportation scenario. It was discovered that converting a conventional motorcycle will lower the life cycle energy required and emissions produced by 72% and 45%, respectively.

Mohd et al (2015) made the MATLAB-Simulink model, which has proven to be a good way to study how energy flows through the EV drivetrain and how well it works. In both driving and regeneration modes, the simulation was run and examined. The controller's capacity to fix errors in the system determines the performance of the EV. This project used a basic controller to keep the battery's input-output power constant and a P-I controller to adjust for voltage errors.

Pedrosa et al (2015) showed how a typical car with an internal combustion engine could be turned into an electric car. This conversion required the development of both engine and battery-charging power converters. The converted electric vehicle, dubbed CEPIUM, is currently being put through field tests in order to validate and improve the technologies created through the development of both an engine and battery-charging power converters. The converted electric vehicle, dubbed CEPIUM, is currently being put through field tests in order to validate and improve the technologies created. The assembly of the major components of the electric vehicle was shown, and the Portuguese regulations regarding vehicle conversion were followed.

Upadhyay et al (2021) performed the simulation of a simple electric vehicle using MATLAB/SIMULINK. An electric vehicle has many advantages and benefits over a hybrid vehicle or one powered by an internal combustion engine. Judging from the simulation, it can be concluded that even the performance of electric vehicles is improving year by year. It is inevitable that EVs are going to be included in daily-driving vehicles in the near future. Reference speed from the FTP75 graph, a 48-volt battery, and a longitudinal driver for driving the vehicle body at the reference speed given.

Hazra and Janardhan Reddy (2021) said that electric vehicles don't have internal combustion engines. Instead, they have electric motors.Noise, vibration, and harshness issues with electric vehicles (EV) are very different from those with internal combustion engines (ICE). This is because the source of the vibration is different. A case study is used to show the different treatment plans that need to be used to ease concerns about source vibration.

The comparison o ICE vehicle and electric vehicle is shown in Figure 4.

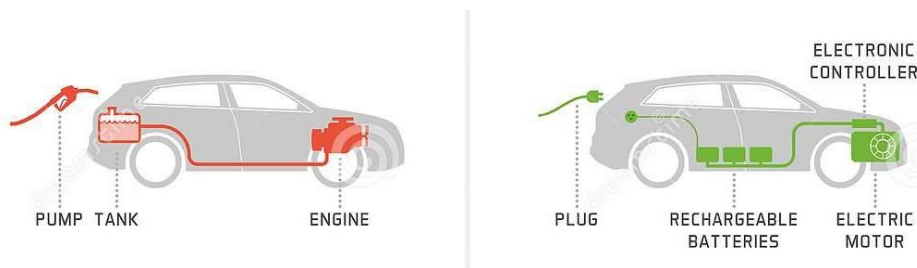

Figure 4 Comparison of ICE Vehicle and Electric vehicle (Courtesy: dreamstime).

2. Materials and methods

The methodology used in context to the present work is presented in a classified manner as shown in Figure 5. The objective of this work is to exhibit and summarise the important aspects for the conversion of ICE to EV in the following categories: ICE technology, EV technology, industrial transportation work, conversion of ICE to EV, which is further categorised as component finalisation, design and analysis of the existing components, fieldwork and mechanical experimentation, and vibration response.

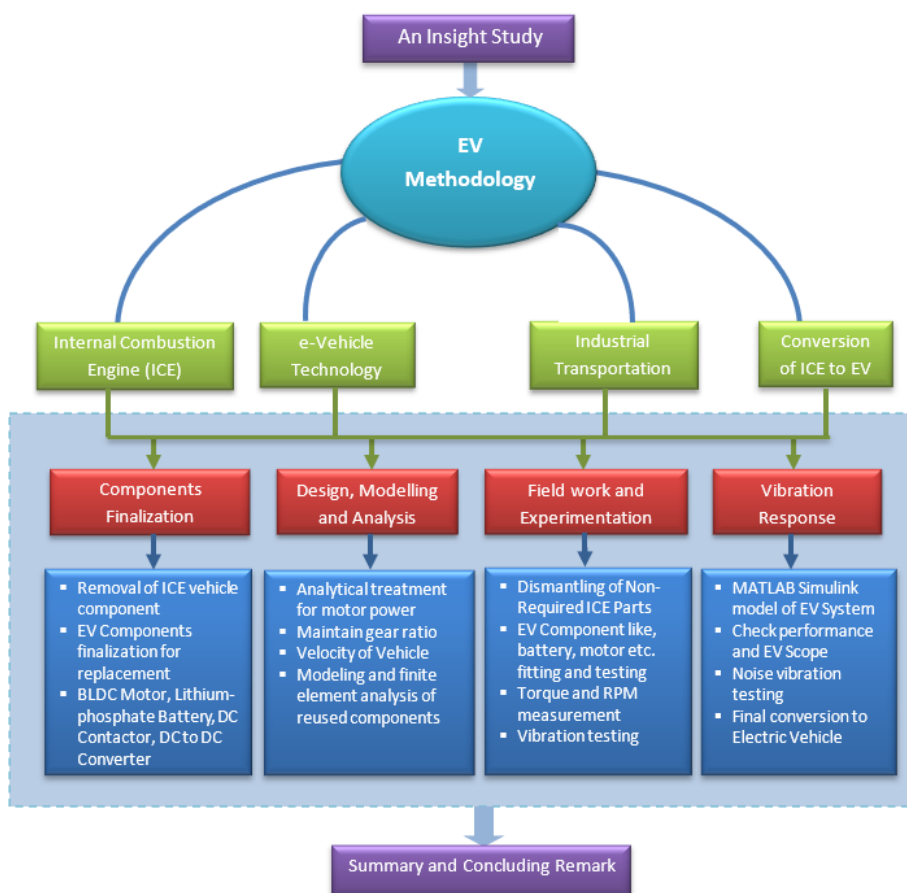

Figure 5 Methodology for conversion of ICE vehicle to EV.

The various stages planned for the research work and its objectives are as follows.

1. To dismantle the IC Engine and remove the piston and engine head from the engine.
2. To mount the electric motor as per the required capacity over the cylinder block.
3. To finalize the battery capacity as per the weight of the vehicle and the distance to be travelled.
4. Design and analysis of the components required for power transmission from the motor to the front wheel to achieve the required speed ratio and velocity ratio.

2.1. Components Used for Conversion

The main components used for the conversion of an IC engine vehicle to an electric vehicle are the motor, battery, DC contactor, DC to DC converter, and accelerator, as shown in Figure 6. An electronically commutated motor is a brushless DC electric motor (BLDC motor or BL motor). This motor is controlled by a controller that regulates the motor's speed and torque. As per the loading capacity of around 250–300 kg, a 3.5-Kw motor with 3000 rpm has been selected for the electric vehicle. The other parameters of the motors are their rated voltage (72 volts), rated current (72 amh), rated speed (3000 rpm), and weight (10726 gm). The weight of the vehicle body is 1000 kg, and as per the requirement of the industry, the speed should not exceed 40 km/hr after conversion to an electric vehicle.

A contactor is a switch that is controlled by electricity and is used to switch an electrical power circuit. It is like a relay, but it can handle more current. Contactors come in a range of forms and sizes, each with its own set of capabilities and features. Unlike a circuit breaker, a contactor is not intended to halt a short-circuit current. A DC-to-DC converter converts one level of DC voltage to another level. The operating voltage of different electronic devices such as ICs and MOSFETs can vary over a wide range, making it necessary to provide a voltage for each device. An accelerator is also known as a gas pedal. It's the pedal on the far-right side of the floor. This pedal regulates the amount of gas supplied into the engine and, as a result, the vehicle's speed (Sun et al 2016; Vrazic et al 2014; Un-Noor et al 2017; Shewate et al 2018; Mohd et al 2015; Dhole et al 2018). The EV block diagram is shown in Figure 7.



Figure 6 Components Used for Conversion.

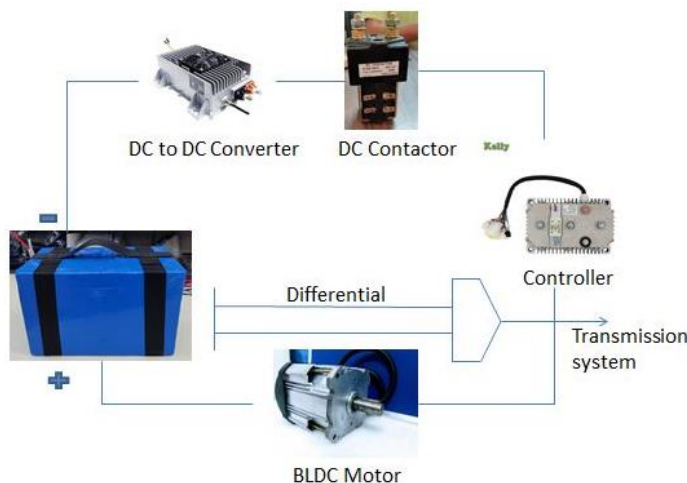

Figure 7 EV's block diagram.

2.2. Field Work

2.2.1. Dismantling of Non-Required Part

The many components available in an ICE vehicle are not required for an electric vehicle. Hence, it is required to disassemble or remove non-required parts to convert it into an EV. As per the study from various works of literature and the market survey, it has been finalised that the parts available at the front side of the vehicle, i.e., with the bonnet, such as the radiator, cooling fan, etc., are removed. Also, the fluid available inside the cooling pipes was emptied. Then I began removing the bonnet surface fittings and their latches. Accordingly, the bonnet has been dismantled with the removal of the electrical components such as the battery, fluid motors, wipers, and so on.

The internal combustion engine is the heart of a fuel vehicle, and it was a very tedious job to remove the complete 796 cc engine from the vehicle as it is connected to many components such as the drive shaft, gear box, etc. and also because of its heavy weight. It was fixed with three mountings. After removing the engine from the car, the whole engine is again dismantled by draining the engine's leftover oil and other fluids. All non-essential parts, such as pistons, engine heads, radiators, coolant, and so on, have been removed because any IC parts are not utilised for EV. The existing engine assembly consists of a cylinder block and a crank shaft, which are only utilised in EVs to transmit power. The transmission system is used for power transmission with an electric motor instead of an IC engine. Other unnecessary equipment such as the silencer, gas tank, catalytic converter, and so on are also removed, which helps to decrease vehicle weight. Some electrical components, such as the alternator and AC compressor, are also removed. Figure 8 shows the engine assembly condition before and after removing the unwanted parts.

For the EV assembly, the cylinder block and crankshaft are kept as they are for power transmission. A motor is mounted on the cylinder block with a 10 mm-thick mounting plate. A toothed pulley with 40 teeth is fixed on the motor shaft, and another driven pulley with 20 teeth is mounted on the crankshaft, and the timing belt meshes with these two pulleys. Because the crankshaft is solely used as a dummy shaft for power transmission, power is passed from the motor to the crankshaft. To accomplish the desired speed of about 40 km/hr, the gearbox with the required number of gears is activated and the other gears are blocked. Power is delivered from the crankshaft to the gearbox and then to the front axle. Batteries are installed in the free space at the rear of the vehicle by removing the rear seats.



Figure 8 Engine assembly condition before and after removing the unwanted parts.

2.2.2. Analytical Treatment

To Figure out how much power goes from the motor to the front axle, you need to know how the crankshaft and gearbox work. The speed in RPM has been calculated at every stage, from motor speed to axle speed, by considering only three gears in the gearbox.

The following weight of the vehicle and its accessories is used to calculate the total load applied to the BLDC motor.

Vehicle weight = 1000kg; Motor weight = 15kg; Battery weight = 25kg; Total load = 1035 kg

The bearing diameter has been considered for calculating Torque, Power and RPM.

Diameter (D) = 0.0485 m Radius (r) = 0.02425 m

Coefficient of friction, $\mu = 0.1$ Motor Speed = 3000 rpm

Weight of car = 1000 kg Force, F = 20000 N

By considering FOS = 2 the torque transmitting capacity and speed in rpm have been calculated.

Torque, $T = F \times \mu \times r = 48.5 \text{ N-m}$

Velocity,
Speed, N = $V = \frac{2\pi r N}{60}$

Speed, N = 318.31 rpm

Power $P = \frac{2\pi N T}{60} = 15.23 \text{ KW}$

Dividing this power with the Reduction ratio, we get (P) = 1.61 KW

Similarly, at power $P = 3.5$ KW the torque is obtained as 48.5 N-m

In Table 2, the power-transmitting capacity has been calculated by taking into account the constant torque and gear ratio. As we know, torque is inversely proportional to speed and directly proportional to power. Hence, based on the calculation, 3.5 kW of motor power has been selected where the required speed can be achieved. The graphical representation of power with speed in rpm and velocity in km/hr is shown in Figures 9 and 10.

Table 2 Analytical Selection of Torque, Power, and RPM.

Sr.no	Gear ratio	Power (KW)	Speed (RPM)	Velocity (KMPH)
1	4.38	1.61	318.31	29.88
2	4.38	3.2	636.23	51.58
3	4.38	3.5	723.86	75.80
4	4.38	4.1	814	134.47

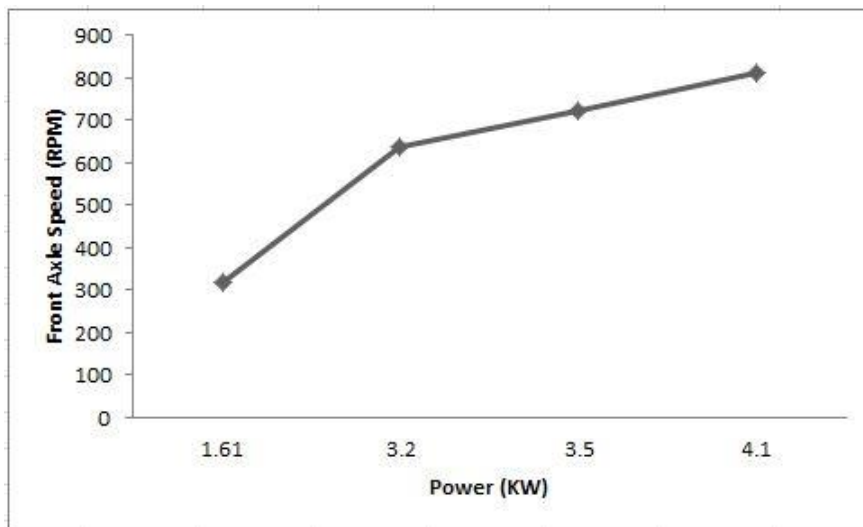

Figure 9 Motor power vs EV speed in rpm.

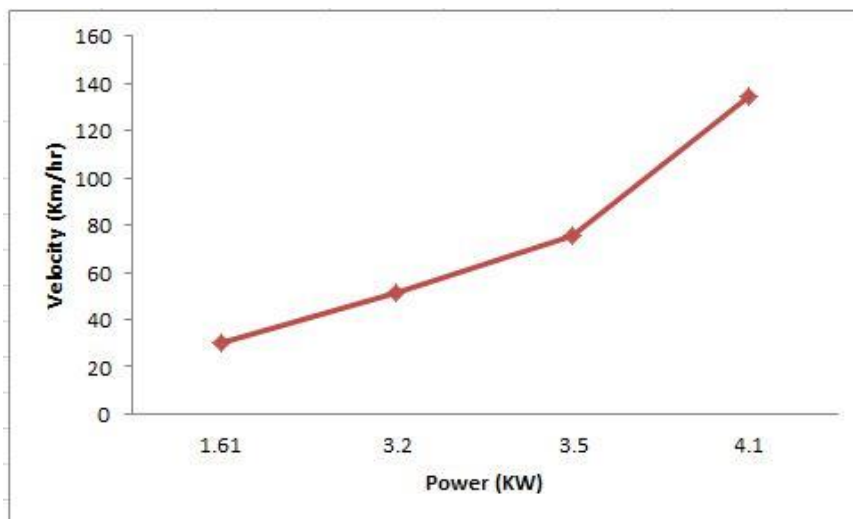

Figure 10 Motor power vs velocity of EV in km/hr.

2.2.3. Reused Components

Some components in the transmission system have not been replaced and have been kept as they are, as per the industry's limitations on replacement. Accordingly, the belt drive through the engine, crankshaft, and gearbox is kept as is, and the power transmission has been replaced from the IC engine to the BLDC motor. Hence, an analysis has been carried out on the belt drive and crankshaft for safe design. A FE analysis has been carried out to check for its safe design (Gandoman et al 2021). A 20-tooth pulley is mounted on the transmission shaft, and a 40-tooth pulley is mounted on the motor shaft. The centre distance between both pulleys is 480 mm.

The concept of timing belt drives for power and motion transfer was relatively new. Timing belts are commonly utilized in cars for power transmission and movement. The primary function of timing belt drives is to convey power and motion from the driving shaft to the driven shaft. The CAD model of toothed pulley, timing belt drive and crankshaft used for the FE analysis is shown in Figure 11, Figure 12, and Figure 13.

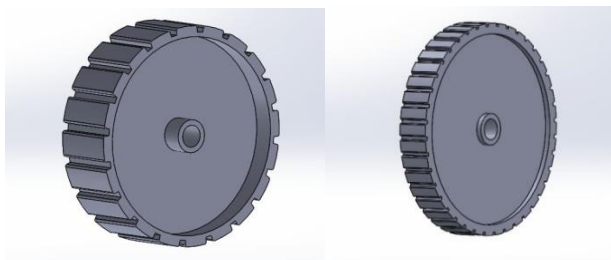

Figure 11 20 tooth and 40 tooth pulley 3D model.

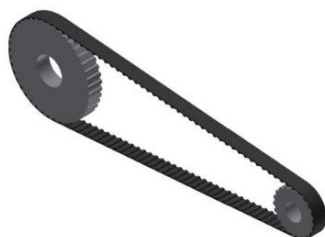

Figure 12 Timing belt drive assembly 3D model.

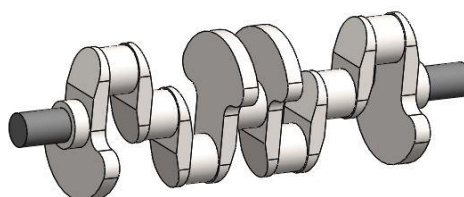

Figure 13 3D model of crankshaft.

3. Result and discussion

3.1. Numerical Analysis of EV

EVs have been analysed numerically in two different ways to back up the fieldwork and mechanical experiments that were done to find out how they respond to noise and vibration. To get around the limitations of the industry, the crankshaft and gearbox of an ICE vehicle are used to send power from the motor to the front axle of an electric vehicle. Hence, it is necessary to analyse the crankshaft for the torque transmission capacity of an electric motor. Also, prior to conversion to EV, it is necessary to check its performance using the mathematical tool MATLAB. Hence, the MATLAB Simulink model is prepared to check the EV's performance in the form of motor speed, motor torque, battery SOC, battery current, and fuel economy (*Electric Vehicles And Its Different Types | Explained*, n.d.) (Pedrosa et al 2015; Dusane et al 2016; Upadhyay et al 2021; Hazra and Janardhan Reddy 2021).

3.2. FE Analysis of Crankshaft

Engine crankshafts and shafts are subjected to a large amount of cyclic loading during service. Crankshafts can break when they are subjected to cyclic loads that are less stressful than the material's yield strength or ultimate strength. This can cause sudden overloads, bad engine operation, bad engine maintenance, and fatigue failures. Power shafts, which are the most highly stressed component, are more likely to fail due to fatigue. By using finite element analysis and comparing the results to analytical results, the static and dynamic stresses have been measured. It has been seen that the static analysis and the analytical model are very close to each other, and the dynamic analysis shows that the stress is below the limit of the material's strength. Hence, the available crankshaft can be reused for the electric vehicle. The mesh model of the crankshaft is shown in Figure 14, and the stresses acting on the crankshaft are shown in Figures 15 and 16. The results of stress are given in Table 3.

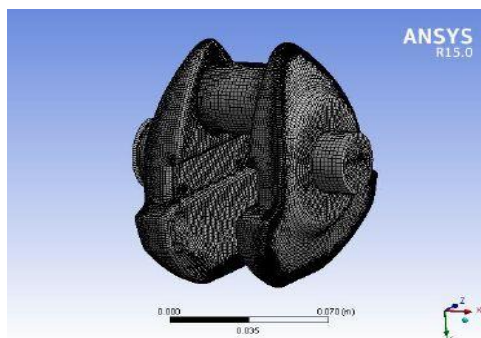

Figure 14 Mesh model of crankshaft.

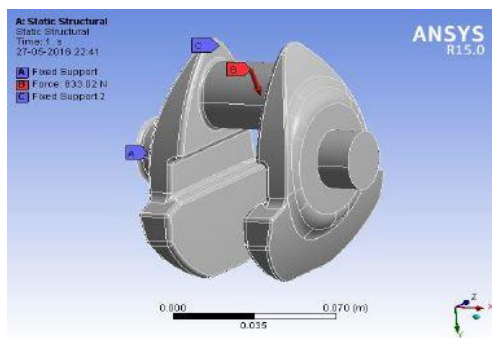

Figure 15 Model of crankshaft.

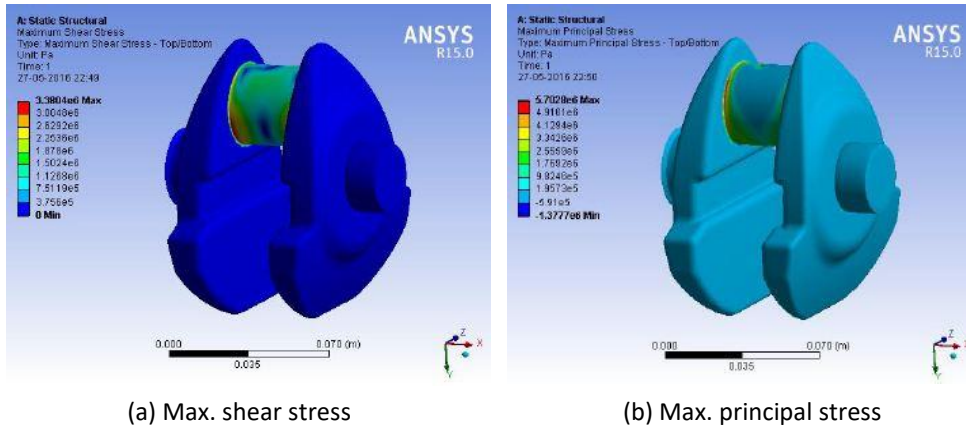

Figure 16 Stresses on crankshaft for static analysis.

Table 3 Comparison Between Theoretical and FEA Values.

Parameters	Theoretical	Static	Dynamic
Maximum Principal Stress (N/mm ²)	5.43636	5.7028	13.835
Maximum Shear Stress (N/mm ²)	3.69163	3.3804	6.8772
Total Deformation (mm)	0.00062601	0.0006553	0.0000018
Equivalent Von Mises Stress (N/mm ²)	6.3671	5.8899	13.253

3.3. FE analysis of Timing Belt and pulley

The timing belt, which has all of the above technical properties, is put through different torque values, and the changes in stress between the belt teeth and pulley are then measured. The driving pulley is smaller than the pulley in drives. It is vital to set various constraints on the model in order to get the driving conditions closer to real-world situations. Also, it has been observed that the available timing belt drive can be reused when converting into an electric vehicle. The von Mises stress for a moment at 7.5 N-m and 30 N-m is shown in Figures 17 and 18.

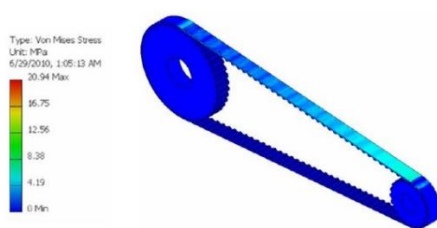

Figure 17 Von-mises stress at M = 7.5 N-m.

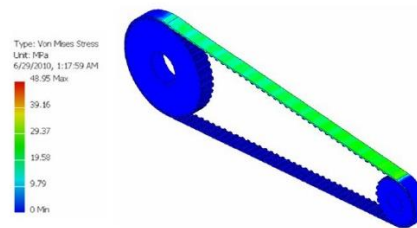

Figure 18 Von-mises stress at M = 30 N-m.

3.4. Simulink Modeling and vibration analysis

A BMS (Battery Management System) is an electrical system in a battery pack that is linked to the battery of a vehicle, such as a car. It keeps the battery in its safe working zones, calculates and monitors its data, and controls and authenticates it all at the same time. A link between the State of Charge (SOC) and the State of Estimation (SOE) of a battery has been established (da Silva and Urbanetz 2019). The Simulink model for simulation using FTP 75 as a drive cycle is shown in Figure 19, and its result is shown in Figure 20.

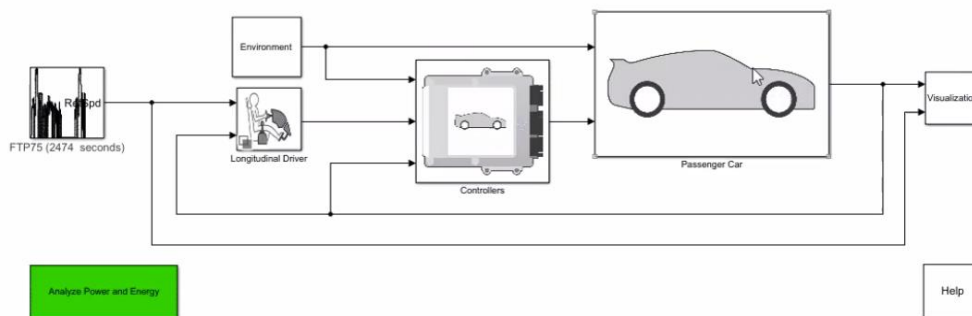

Figure 19 Simulation using FTP 75 as drive cycle.



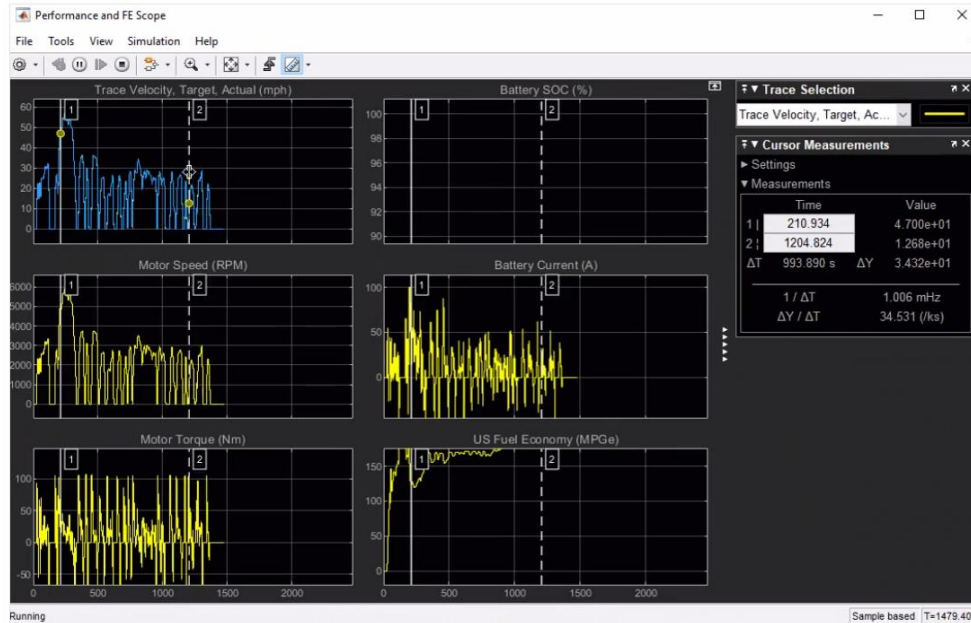

Figure 20 Simulation results of EV using Simulink.

Because there are numerous Acceleration and De-Acceleration Profiles in the Speed Comparison Profile, we may deduce that the SOC drops from 100 percent to 70-75 percent in around 1874 seconds. For 60 seconds, we simulated a WOT (wide open throttle) drive cycle source. In WOT, the car accelerates for 30 seconds before decelerating after that. In WOT, the distance travelled is 8 kilometres.

The battery SOC reduces from 100 to 98.2 percent in the first 30 seconds, then the regenerative power provided by the motor charges the battery pack from 98.2 percent to 98.8 percent in the next 30 seconds. The use of the energy management system (EMS) in EV applications for regulating battery heating and cooling has significantly boosted battery dependability and stability. Unfortunately, the efficiency of electric cars is reduced owing to heat issues and deep-dive distance loss. Furthermore, heat effects caused by the electrochemical process caused EMSs to be incorrect and unstable. It has been reported that using a supercapacitor (SC) in the energy storage system (ESS) reduces issues with dynamic instability. Furthermore, the EMSs technology optimisation technique has the potential to dramatically reduce battery ageing and power constraint issues. With all these examinations, the Maruti 800 car model has been converted from an internal combustion engine vehicle to an electric vehicle, and the converted model is shown in Figure 21.



Figure 21 Converted electric vehicle from internal combustion engine vehicle.

Electric vehicles are far quicker than combustion vehicles. This is due to the fact that electric vehicles can create high torque from the start, whereas combustion engines get such torque after gaining speed. It offers electric vehicles an advantage in terms of launch speed and allows them to accelerate from 0 to 60 mph in less time. The absence of kilograms of metal beneath the hood contributes significantly to the lightweight element. And, because there are no moving parts, the cost of maintenance is substantially cheaper - forget about changing oil; the battery will be the most expensive recurring expenditure. Universal components such as the windshield and vehicle glass, wipers, and tyres will continue to require maintenance.

Electric vehicles use Lithium-ion batteries that must be recharged. The capacity of Lithium-ion technology to store power declines over time due to its nature. Owners of electric vehicles might expect to drive less miles over time. However, it has much improved. And Tesla is hard at work on a Lithium-ion alternative that will transform even smaller products like mobile phones and laptop computers.

Because electric vehicles do not utilize combustion engines, the tailpipe emits nearly little pollution. Climate change is one of the most serious threats to humanity. With ice caps melting at an alarming rate, countries all around the world are



witnessing severe changes in their climates, and wildlife is suffering as well. The fight for environmentally friendly vehicles is becoming increasingly crucial in these times.

Although the number of electric vehicles on the road is growing, it is still light years away from replacing every combustion vehicle on the world. It is still considered a first-world luxury.

As per (Hazra and Janardhan Reddy 2021), Internal combustion engines are replaced with electric motors in electric vehicles. As a result, the source vibration's characteristic changes. Because of the difference in source vibration, the noise, vibration, and harshness (NVH) issues in electric vehicles (EV) differ significantly from those in internal combustion engines (ICE). A case study demonstrates the various treatment strategies needed to alleviate source vibration concerns during the electric car development phase. The difference in the source noise between the internal combustion engine and electric vehicle is shown in figure 22. Figure 22 demonstrates the high-order motor resonance at the 48th order in EV as compared to the motor resonance at the 2nd order in ICE.

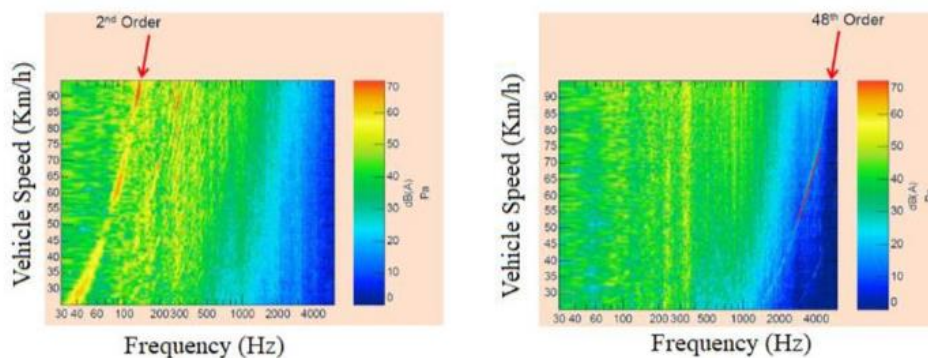

Figure 22 Source noise comparison between internal combustion engine and electric vehicle.

The source vibration of the ICE is shown in figure 20, where the 2nd order vibration is prominent due to engine unbalance forces. The isolation effect for both ICE and EV has been measured during vibration measurement at different three mount transfer path from the powertrain to the cabin using FFT analyzer of make SVANTEK, UK, model SVAN958. A 240 Hz frequency is identified as the contribution of transfer path which is resonating with the source. In an EV, the situation is different because the surface vibration and resonance of the powertrain were not present at low frequencies.

4. Conclusions

For transmission of power from an electric motor to the axle using crankshaft is accomplished by means of electric vehicles. A pulley with 40 teeth is attached to the motor shaft, and a mounting plate 10 mm thick secures the motor to the cylinder block. Battery packs can be installed in the large space created by the collapsed rear seats; the vehicle's ability to transmit power will depend on the gear ratio and torque available.

The integrity of the components' designs have been verified through finite element analysis. Finite element analysis has been used to determine the static and dynamic stresses. Changes in stress between the timing belt's teeth and the pulley are measured as the belt is subjected to a range of torque values. According to the time-to-speed comparison profile, it takes 1874 seconds for the SOC to decrease from 100% to 70%-75%. Battery dependability and stability have been greatly improved by the use of the energy management system (EMS) in EV applications; however, heat problems and deep-dive distance loss reduce the efficiency of electric cars. Vibration measurements at various three-mount transfer paths from the engine to the passenger compartment have revealed the isolation effect for both ICE and EV. The frequency of 240 hertz is determined to be the transfer path's contribution that resonates with the original.

Before assembly of the electric vehicle, the motor speed, motor torque, battery current has been tested using Simulink model. As per the results of Simulink model the converted electric vehicle can run with the velocity of 40 km/hr for green transportation technology. The vibration response represents that the source vibration in electric vehicle differs significantly than that of the internal combustion engine vehicle.

Ethical considerations

Not applicable.

Conflict of Interest

The authors declare that they have no conflict of interest.

Funding

This research did not receive any financial support.

References

- Ala G, Colak I, Di Filippo G, Miceli R, Romano P, Silva C, Valtchev S, Viola F (2021) Electric Mobility in Portugal: Current Situation and Forecasts for Fuel Cell Vehicles. *Energies* 14:7945. DOI: 10.3390/EN14237945
- Alosaimi W, Ansari MTJ, Alharbi A, Alyami H, Ali S, Agrawal A, Khan RA (2021) Toward a Unified Model Approach for Evaluating Different Electric Vehicles. *Energies* 14:6120. DOI: 10.3390/EN14196120
- da Silva JE, Urbanetz J (2019) Converting a Conventional Vehicle into an Electric Vehicle (EV). *Brazilian Archives of Biology and Technology* 62:19190007. DOI: 10.1590/1678-4324-SMART-2019190007
- Dhole PA, Kumbhalkar MA, Jadhav GV, Dalwai AS (2018) Recent Trends in Transportation Technology as Hybrid-Electric Vehicle: A Review. 1st National Conference On Recent Innovations in Mechanical Engineering (NCRIME-2018):4–8.
- Dotoli M, Rocca R, Giuliano M, Nicol G, Parussa F, Baricco M, Ferrari AM, Nervi C, Sgroi MF (2022) A Review of Mechanical and Chemical Sensors for Automotive Li-Ion Battery Systems. *Sensors* 22:1763. DOI: 10.3390/S22051763
- Dusane SV, Dipke MK, Kumbhalkar MA (2016) Analysis of Steering Knuckle of All Terrain Vehicles (ATV) Using Finite Element Analysis. *IOP Conference Series: Materials Science and Engineering* 149:012133. DOI: 10.1088/1757-899X/149/1/012133
- Ewelina SM, Grysa K (2021) Assessment of the Total Cost of Ownership of Electric Vehicles in Poland. *Energies* 14:4806. DOI: 10.3390/EN14164806
- Gandoman FH, Ahmed EM, Ali ZM, Berecibar M, Zobaa AF, Aleem SHEA, Ali EM, Berecibar ZM, Zobaa M, Aleem A, Reliability SHE (2021) Reliability Evaluation of Lithium-Ion Batteries for E-Mobility Applications from Practical and Technical Perspectives: A Case Study. *Sustainability* 13:11688. DOI: 10.3390/SU132111688
- GoMechanic (2022) Electric Vehicles And Its Different Types. Available in: <https://gomechanic.in/blog/electric-vehicles-types-explained/>. Accessed on: February 26, 2023.
- Hazra S, Janardhan Reddy K (2021) A Comparative Study of Source Vibration between the Electric Motor and Internal Combustion Engine Application for Passenger Vehicles. *SAE Technical Papers*. DOI: 10.4271/2021-01-1243
- Kumbhalkar MA, Bhope DV, Vanalkar AV (2016) Analysis of Rail Vehicle Suspension Spring with Special Emphasis on Curving, Tracking and Tractive Efforts. *IOP Conference Series: Materials Science and Engineering* 149:012131. DOI: 10.1088/1757-899X/149/1/012131
- Lashari ZA, Ko J, Jung S, Choi S (2022) Choices of Potential Car Buyers Regarding Alternative Fuel Vehicles in South Korea: A Discrete Choice Modeling Approach. *Sustainability* 14:5360. DOI: 10.3390/SU14095360
- Mamun KA, Islam FR, Haque R, Chand AA, Prasad KA, Goundar KK, Prakash K, Maharaj S (2022) Systematic Modeling and Analysis of On-Board Vehicle Integrated Novel Hybrid Renewable Energy System with Storage for Electric Vehicles. *Sustainability* 14:2538. DOI: 10.3390/SU14052538
- Mohd TAT, Hassan MK, Aziz WMKA (2015) Mathematical modeling and simulation of an electric vehicle. *Journal of Mechanical Engineering and Sciences* 8:1312-1321. DOI: 10.15282/jmes.8.2015.6.0128
- Novotny A, Szeberin I, Kovács S, Máté D (2022) National Culture and the Market Development of Battery Electric Vehicles in 21 Countries. *Energies* 15:1539. DOI: 10.3390/EN15041539
- Pedrosa D, Monteiro V, Gonçalves H, Martins JS, Afonso JL (2015) A case study on the conversion of an internal combustion engine vehicle into an electric vehicle. *IEEE Vehicle Power and Propulsion Conference, VPPC 2014*. DOI: 10.1109/VPPC.2014.7006994
- Shewate S, Kumbhalkar MA, Sonawane Y, Salunkhe T, Savant S (2018) Modelling And Simulation Of Regenerative Braking System For Light Commercial Vehicle-A Review. *IOSR Journal of Mechanical and Civil Engineering* 7:65-71.
- Un-Noor F, Padmanaban S, Mihet-Popa L, Mollah MN, Hossain E (2017) A Comprehensive Study of Key Electric Vehicle (EV) Components, Technologies, Challenges, Impacts, and Future Direction of Development. *Energies* 10:1217. DOI: 10.3390/EN10081217
- Upadhyay A, Dalal M, Sanghvi N, Singh V, Nair S, Scurtu IC, Dragan C (2021) Electric Vehicles over Contemporary Combustion Engines. *IOP Conference Series: Earth and Environmental Science* 635:012004. DOI: 10.1088/1755-1315/635/1/012004
- Veza I, Abas MA, Djamari DW, Tamaldin N, Endrasari F, Budiman BA, Idris M, Opia AC, Juangsa FB, Aziz M (2022) Electric Vehicles in Malaysia and Indonesia: Opportunities and Challenges. *Energies* 15(7):2564. DOI: 10.3390/EN15072564
- Vrabie C (2022) Electric Vehicles Optimism versus the Energy Market Reality. *Sustainability* 14:5388. DOI: 10.3390/SU14095388
- Vrazic M, Vuljaj D, Pavasovic A, Paukovic H (2014) Study of a vehicle conversion from internal combustion engine to electric drive. *ENERGYCON 2014 - IEEE International Energy Conference* 1544-1548. DOI: 10.1109/ENERGYCON.2014.6850628
- Vu TM, Moezzi R, Cyrus J, Hlava J, Petru M (2021) Parallel Hybrid Electric Vehicle Modelling and Model Predictive Control. *Applied Sciences* 11:10668. DOI: 10.3390/APP112210668
- Wahid MR, Budiman BA, Joelianto E, Aziz M (2021) A Review on Drive Train Technologies for Passenger Electric Vehicles. *Energies* 14:6742. DOI: 10.3390/EN14206742
- Xuan PY, Henz M, Weigl JD (2013) Environmental impact of Converted Electrical Motorcycle. *World Electric Vehicle Journal* 6:1136–1143. DOI: 10.3390/WEVJ6041136